

peugeot504.info



# PEUGEOT

# 504

## PICK UPS





## PEUGEOT 504 PICK-UP RANGE

The Peugeot 504 is the Real pick-up - a rugged and versatile work-horse offering class-leading payloads of up to 1265kg. The three model range gives a choice of Standard trim level combined with either the 1.8L petrol or 2.3L diesel engine or GL trim with the 2.3L diesel.

Whatever combination you choose to meet your particular needs the specification includes a five-speed full synchromesh gearbox for economy and a limited slip rear differential for extra grip under slippery conditions.

Externally GL models feature a heavy duty nudgebar and durable loadliner to protect its rugged good looks. Additionally all 504 pick-ups have a comprehensive 12 month unlimited mileage warranty and the bodywork is protected by a nine-stage paint process.

Introduction 2/3

---

Interiors 4/5

---

Capacities 6/7

---

Cutaway 8/9

---

Specifications 10

---

Dimensions/Colours 11

---

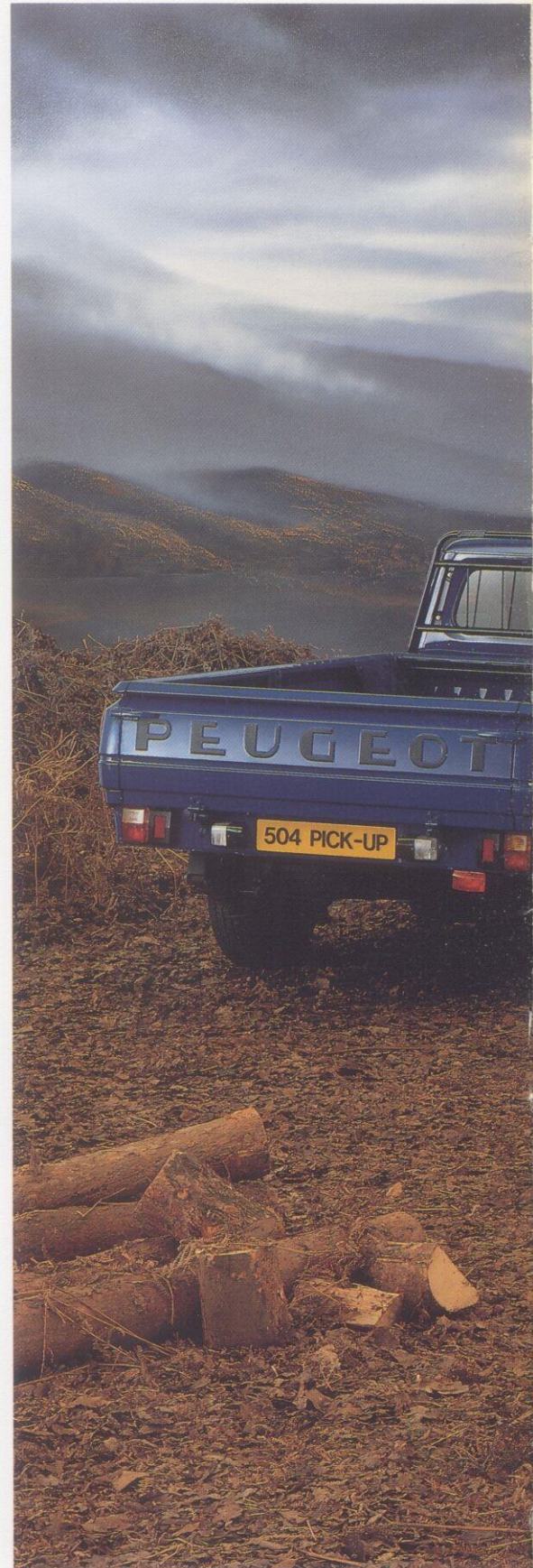



TRUCKS PICK-UP 504 - 400 - 1984





## PEUGEOT 504 - CAR LIKE COMFORT

There are two trim levels available with the Peugeot 504 - Standard and GL. Although each was designed with comfort and efficiency in mind the GL offers a little more refinement.

Both models have a practical, reach adjustable three person bench seat. Door pockets and a lockable glove box provide ample storage space and there are two door mirrors, twin sun visors, door armrests, a dipping interior mirror and an illuminated cigar lighter.



The comprehensive instrumentation includes a quartz clock, a trip odometer and a number of diagnostic warning lights. There are door courtesy switches for the interior light and a variable-speed fan regulates heating and ventilation.

The 504 Standard features hard-wearing easy-clean vinyl trim and a practical rubber floor mat.

In the higher specification 504 GL the seat is trimmed in an attractive heavy duty cloth with vinyl side panels. There are matching padded head



restraints and a carpeted floor for extra comfort. There is also a Clarion security-coded radio and stereo cassette player complete with twin speakers.



1981-1984 1.6 12 V 1.8 1500 2.0 1500 2.0 1600

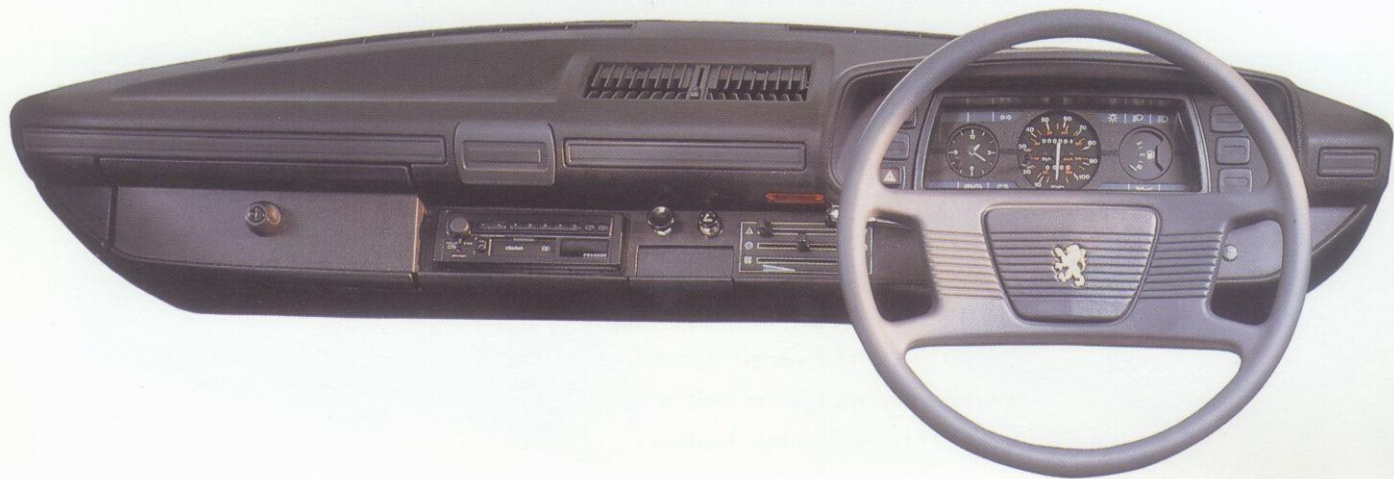



## PEUGEOT 504 - THE REAL PICK-UP

Two powerful engines are available for 504 pick-ups. The robust 1.8L petrol engine has electronic breakerless ignition, develops 53kW (80PS) at 5500 rpm and runs on unleaded fuel. Alternatively the well-proven 2.3L Peugeot diesel features rapid pre-heat plugs for reliable cold starting and develops 46.0kW (70PS) at 4500rpm with excellent low range torque.

There is a cab protection frame with integral ladder type rack. The 504 is fitted with dual circuit servo-assisted brakes with front coil springs and dual rate leaf springs at the rear to cope with hefty loads and tough working conditions.

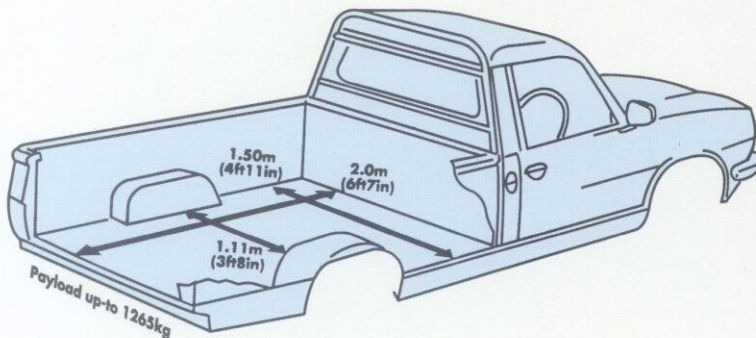

The strong load box sits well clear of the ground on 15" wheels and provides a spacious 2.0m x 1.5m (6'7" x 4'11") load area which can carry class leading gross payloads up to 1265kg (Standard) or 1213kg (GL). Between the wheel arches there is a class leading width of 1.11m (3'8") and the double skinned tailgate lowers to 90 or 180 degrees for versatile access. The spare wheel is mounted in a wind-down carrier under the ribbed load deck.

The GL has the added benefit of a heavy duty nudgebar and a tough loadliner to protect the loadbox.



Extra cost options for the Standard include the loadliner and nudgebar, and there is a GRP hardtop available on both models for increased loadspace and security. A tow bar and tonneau cover are among the other accessories available.







# PEUGEOT 504 - CUT OUT FOR WORK

Choice of Standard or GL specification. 504 Standard has practical vinyl upholstery and rubber floor mats. 504 GL has hard-wearing cloth trim, twin head restraints and a security coded radio/stereo cassette player.

Saloon car comfort and practical three person bench seat. (GL model illustrated).

Choice of 1.8L petrol or Peugeot's proven 2.3L diesel engine both with a 5-speed full synchromesh gearbox.

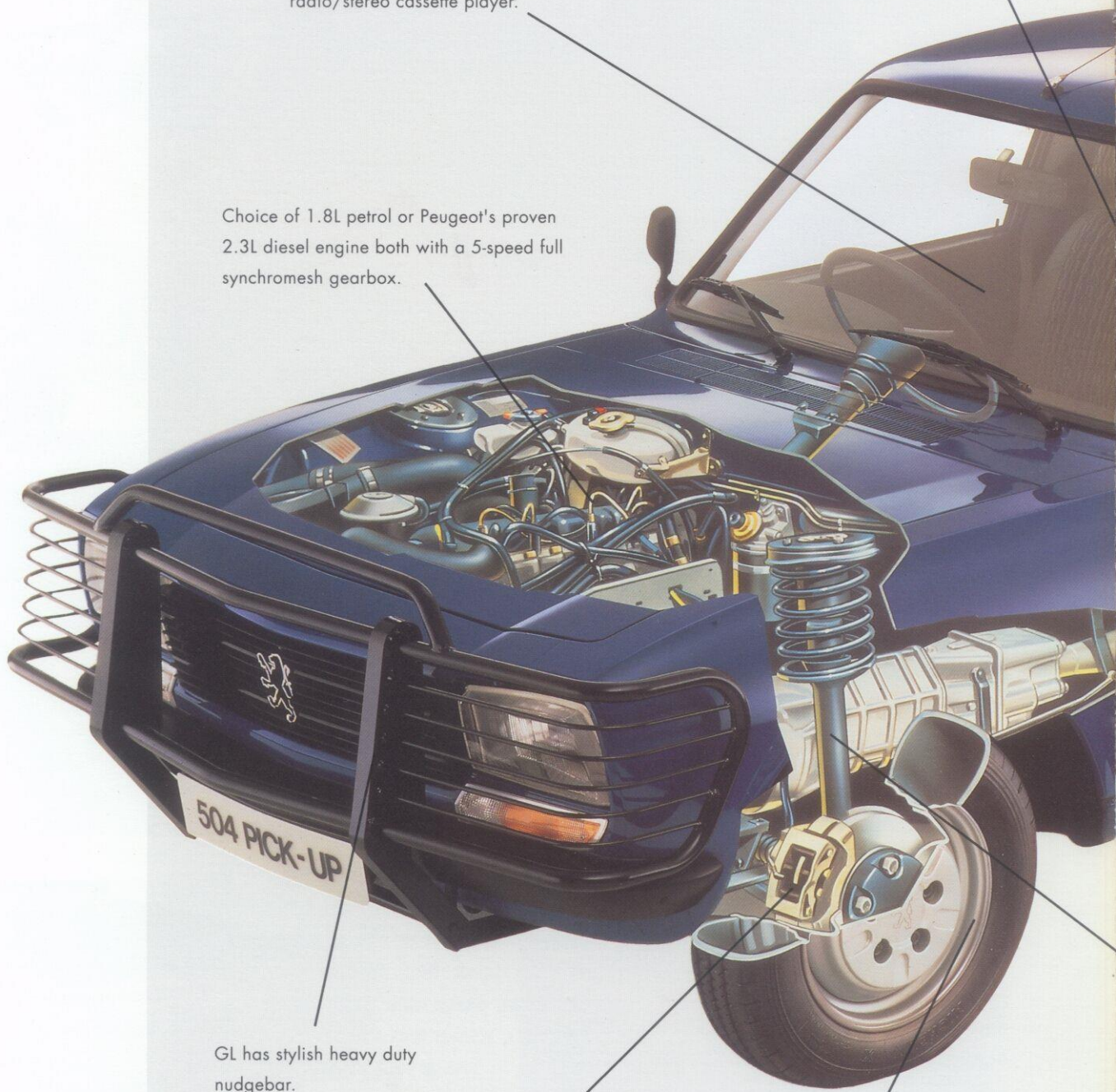

GL has stylish heavy duty nudgebar.

Servo assisted brakes with load apportioning valve for safe braking when laden or unladen

15" wheels give excellent ground clearance



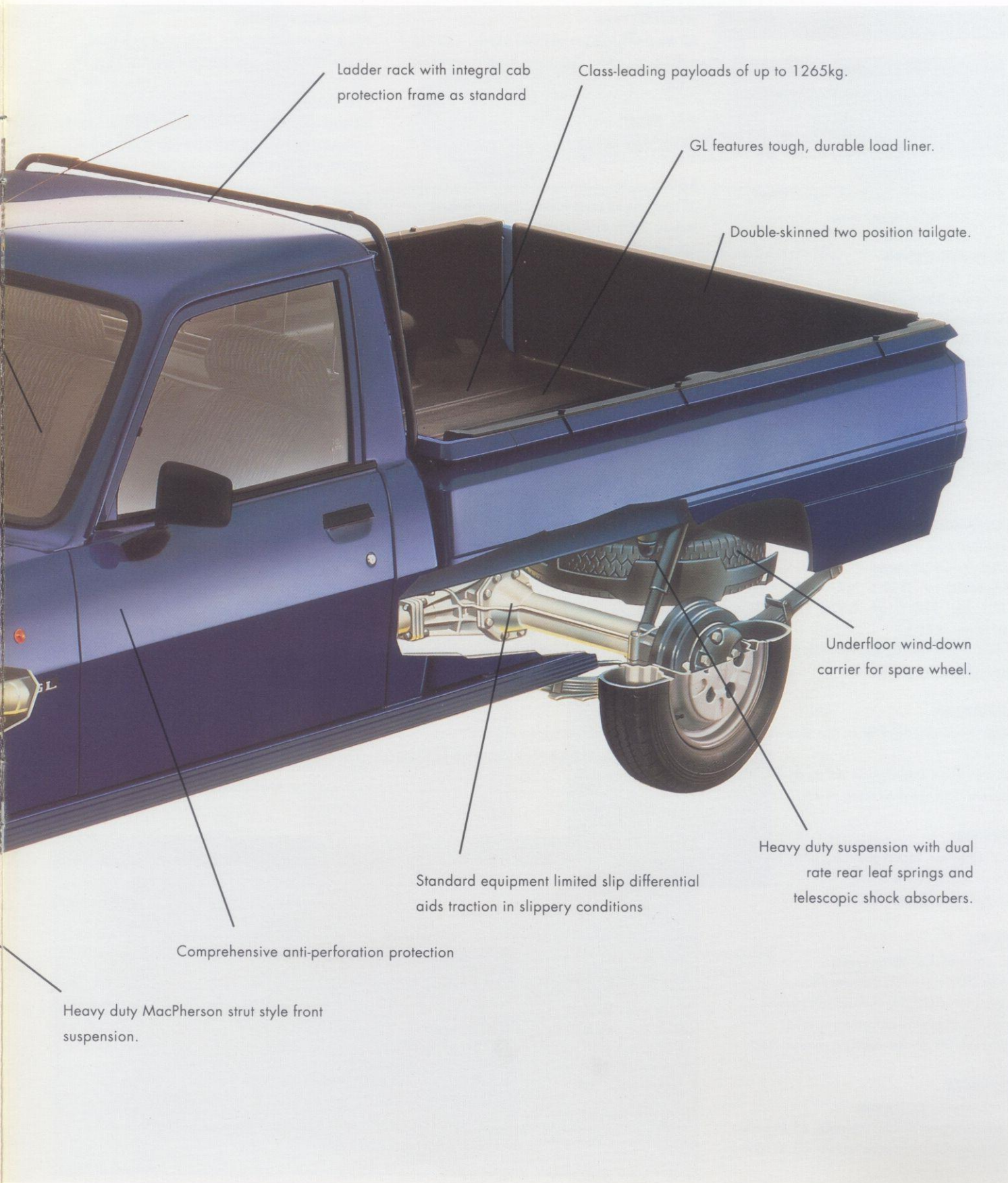

Ladder rack with integral cab protection frame as standard

Class-leading payloads of up to 1265kg.

GL features tough, durable load liner.

Double-skinned two position tailgate.

Underfloor wind-down carrier for spare wheel.

Heavy duty suspension with dual rate rear leaf springs and telescopic shock absorbers.

Standard equipment limited slip differential aids traction in slippery conditions

Comprehensive anti-perforation protection

Heavy duty MacPherson strut style front suspension.



# 504 SPECIFICATION

## SPECIFICATION

### 2.3L PEUGEOT DIESEL ENGINE

Capacity: 2304cc

Bore/Stroke: 94mm x 83mm

Max Power: 70PS (46.0 kW) @ 4500 rpm

Max Torque: 13.4 mkg (131 Nm) @ 2000 rpm

Compression Ratio: 22.2:1

Fuel System: Naturally aspirated, indirect diesel injection with rapid pre-heat plugs.

### 1.8L PETROL ENGINE

Capacity: 1796cc

Bore/Stroke: 84mm x 81mm

Max Power: 80PS (53.0 kW) @ 5500 rpm

Max Torque: 14.5 mkg (142 Nm) @ 2500 rpm

Compression Ratio: 8.8:1

Fuel System: Down draught carburettor, manual choke. Electronic breakerless ignition. Set to run on unleaded 95 RON petrol.

**Note:** All engines have 4 cylinder in-line longitudinal layout, alloy cylinder head and thermostatic cooling fan.

### TRANSMISSION

Rear wheel drive. Full synchromesh 5-speed gearbox. Limited slip rear differential.

**All models:** 1st: 3.59:1 2nd: 2.09:1 3rd:

1.37:1 4th: 1.00:1 5th: 0.82:1 Rev: 3.63:1

Final Drive: 4.88:1

**Clutch:** 215mm (8.5in) diameter, diaphragm spring. Single plate.

### SUSPENSION

**Front:** Independent MacPherson type struts with anti-roll bar

**Rear:** Dual rate semi-elliptical leaf spring with telescopic shock absorbers acting on a rigid beam axle.

### STEERING

Rack and pinion, impact absorbing safety steering column. 4.5 turns lock to lock.

Turning Circle: Overall 12.0m (39ft).

### BRAKES

Servo assisted, dual circuit system.

**Front:** 273mm (10.8in) diameter discs.

**Rear:** 255mm (10.0in) diameter self-adjusting drums. Load-sensitive proportioning valve.

Mechanical handbrake operating on rear wheels.

### ELECTRICAL

12 volt negative earth system.

**Petrol models:** 50 Amp alternator, 45 Ah battery.

**Diesel models:** 50 Amp alternator, 60 Ah battery.

### WHEELS/TYRES

**All Models:** 15in pressed steel wheels. 185 R15 radial tyres. Under deck spare wheel in wind-down carrier.

### FUEL TANK

64 Litres (14.0 gallons)

### BODY

All steel integral construction. *Standard features include:* •Fully enclosed cab •Two hinged cab doors with wind-down windows •Laminated windscreen •Two rear view door mirrors •Ribbed load deck •Double skinned tailgate can be lowered 90 or 180 degrees •Flat-topped wheel arches •Integral ladder rack and cab protection frame •Metal lashing hooks.

### ANTI-CORROSION PROTECTION

Extensive anti-corrosion protection including wax injected box sections and PVC underseal applied to vulnerable underbody areas.

## INTERIOR FEATURES

### DASHBOARD

*Standard models have:* •Steering wheel with centre horn push •Variable heater controls •Dastop air vents •Additional windscreen demist vents •Ashtray •Illuminated switches •Bonnet release •Illuminated cigar lighter •Lockable glovebox

*In addition GL models have:* •Security - coded radio cassette player.

### STALK CONTROLS

•Two speed windscreen wipers with intermittent wipe/electric screen wash •Turn indicators/headlamp switch.

### INSTRUMENT PANEL

•Mph/Kmph speedometer •Trip odometer •Fuel gauge •Analogue quartz clock •Warning lights for low oil pressure, alternator, water temperature, low fuel level, sidelight on, headlamps on, main beam, turn indicator, handbrake on warning light. Diesel engines have warning lights for rapid pre-heat plugs. Petrol engines have a choke-on warning light.

### SEATS

Three person bench seat •Reach adjustment •Two padded head restraints (on GL) •Inertia reel seatbelts for driver and nearside passenger •Lap belt for centre passenger.

### TRIM

**Standard:** •Hardwearing vinyl seat trim •Rubber floor mat.

*GL In addition to Standard models have:*

•Hardwearing cloth seat trim with vinyl side panel •Carpeted cab floor.

### ADDITIONAL FEATURES

**Standard:** •Twin sunvisors •Dipping rear view mirror •Cab light with door operated courtesy switches •Radio pre-equipment •Door pockets •Door armrests.

*GL In addition to Standard models have:* •Twin door speakers

## EXTERIOR FEATURES

**Standard models:** •Halogen dim dip headlamps •Front turn indicators •Side repeat indicators •Rear turn indicators •Combined rear stop/tail lights •Rear fog guard lamp •Reversing light •Centre wheel trims.

*GL In addition to Standard models have:* •Front heavy duty nudgebar •ABS plastic loadliner •Locking fuel filler cap

## WEIGHTS

| Peugeot 504   | Standard |        | GL     |
|---|----------|--------|--------|
|   | Petrol   | Diesel | Diesel |
| Payload* (kg):  | 1265     | 1265   | 1213   |
| Kerbside Weight (kg):                                 | 1250     | 1330   | 1382   |
| GVW (Gross Vehicle Weight) (kg):                      | 2515     | 2595   | 2595   |
| Plated front axle (kg):                               | 950      | 950    | 950    |
| Plated rear axle (kg):                                | 1750     | 1750   | 1750   |
| GTW (Gross Train Weight) (kg):                        | 3500     | 3500   | 3500   |
| Max towing capacity within GTW - braked trailer (kg): | 1400     | 1400   | 1400   |

Note: Whilst normal payload figures are included for guidance, vehicle payload will depend upon individual gross vehicle weight - less an allowance for any optional equipment fitted and crew members carried. Please check with your Dealer for precise details concerning vehicle payload capacity.



## DIMENSIONS

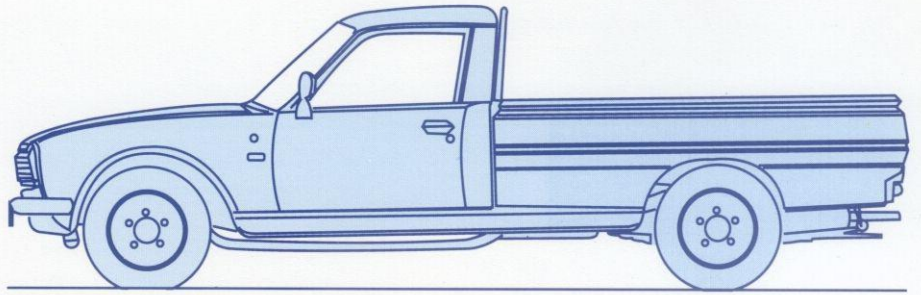
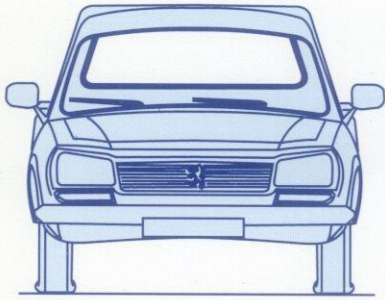

Overall length: 4.75m (15ft 7in) Height unladen: 1.54m (5ft 1/2in) Overall width: (exc. mirrors) 1.71m (5ft 7in) Wheelbase: 3.0m (9ft 10in)  
 Load floor length: 2.0m (6ft 7in) Load floor width 1.50m (4ft 11in) Width between wheel arches: 1.11m (3ft 8in)

## COLOURS



**Steel Grey Metallic**

| COLOUR AVAILABILITY |              |            |                |                |                     |
|---------------------|--------------|------------|----------------|----------------|---------------------|
| Model               | Alpine White | Cherry Red | **Pacific Blue | Express Yellow | Steel Grey Metallic |
| Standard            | ●            | ●          | ●              | S*             | -                   |
| GL                  | ●            | ●          | ●              | S*             | S*                  |

● = Standard colour S\* = Special order colour at extra cost.  
 \*\*N.B. This colour to be replaced by Biscay Blue please consult your dealer for details.

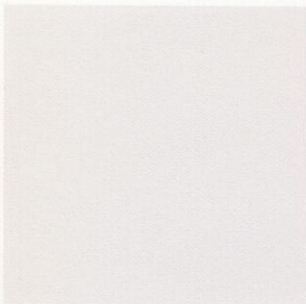

**Alpine White**

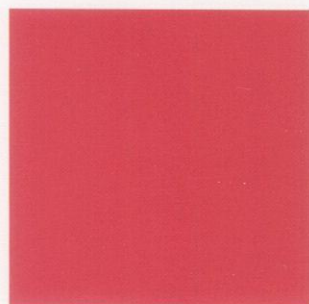

**Cherry Red**

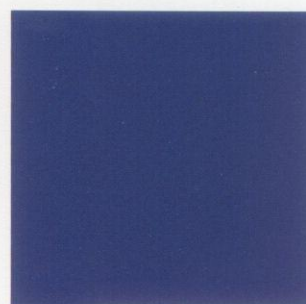

**Pacific Blue**

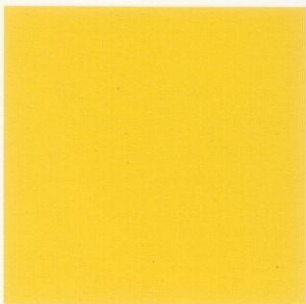

**Express Yellow**

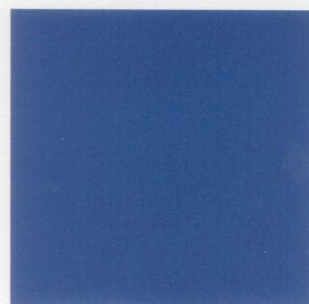

**Biscay Blue**

*Please note colours reproduced may vary from the actual colours due to the limitations of the printing process*



## PEUGEOT SUPPORT



### PEUGEOT IN THE U.K.

Peugeot is fully committed to serving the special needs of commercial vehicle customers in the U.K. with comprehensive after sales support dedicated to keeping your vehicle or fleet on the road.



### PEUGEOT PARTS & SERVICE

Peugeot's product strengths are fully matched by the quality of service and parts supply. State-of-the-art diagnostic equipment is used extensively throughout our dealer network and service procedures are designed to minimise down time. A massive computerised Parts Warehouse operation in Coventry ensures that stocks of dealership parts are maintained at optimum levels at all times.



### WARRANTIES

Every new Peugeot has the benefit of a twelve month unlimited mileage warranty which covers both parts and labour. Extensions of 12 or 24 months are available at extra cost.



### LIONCARE AA

In addition to Peugeot's new vehicle warranties every new Peugeot is protected by the Lioncare assured mobility programme during the first 12 months of ownership. At the core of Lioncare is full AA Membership which includes Home Start, Relay and Relay Plus, a 24 hour breakdown service capable of solving most problems at the roadside every day of the year. If the problem cannot be solved then the AA will transport your vehicle to a Peugeot dealer of your choice.

Special Lioncare Freephone and carphone numbers link you to the Lioncare AA Controllers for priority attention.

When vehicle recovery is involved a replacement vehicle, reimbursement of public transport fares or hotel accommodation may be provided as appropriate (please check with your Peugeot dealer for full details).



### PEUGEOT FLEET SALES

Fleet Sales is a specialised department of Peugeot Talbot able to meet the vehicle needs of all businesses whatever their size.

There is a complete range of passenger cars, car derived vans, compact vans, chassis and crew cabs.

There is an extensive range of finance available including:

- Finance Lease
- Operating Lease
- Contract Hire
- Contract Purchase
- Lease Purchase
- Business Hire Purchase

Plus a network of strategically located Fleet Specialist Dealers.

It is our policy to improve our vehicles continually in every way and we reserve the right to alter specifications at any time without notice. Whilst the details set out in this literature were correct at the time of going to press (May 1991), we are unable to guarantee that no changes in specification have subsequently taken place. Before ordering a vehicle, therefore, you should check with your Peugeot Talbot dealer whether the specification has altered.



Issued by Marketing, Peugeot Talbot Motor Company Limited,  
Aldermoor House, PO Box 227, Aldermoor Lane, Coventry CV3 1LT.